

The All-rounder series

MAGDOS LB - solenoid-diaphragm dosing pumps 0.5 – 15 l/h, up to 16 bar



Reliable dosing of chemicals

The MAGDOS LB solenoid-diaphragm dosing pump is a good-value alternative for simple and continuous dosing tasks. It is especially suitable for water treatment and the process industry.

MAGDOS LB is available for seven capacity ranges. Double-ball valves ensure accurate dosing. The dosing capacity can be controlled from 0 – 100 % by adjusting the stroke frequency. You can thus dose with a flick of the wrist.

MAGDOS LB is a compact solution which only includes the most important elements for reliable dosing.

A coordinated accessory set consisting of hoses, injection nozzles and suction lines enables fast installation, while achieving optimum results.

Easy handling

The dosing pump is equipped with a newly designed stroke solenoid. The stroke frequency is adjusted at the dosing pump for different capacities. The pump is externally controlled by switching the power supply of the pump on and off.

As a plug & play dosing pump with a long-range power supply unit, it is ready for an immediate and world-wide application without any restriction. For the first time, a new calibration functionality for the adjustment of the capacity by the user is applied.

MAGDOS LB can be mounted on the wall in three different positions - upright, left-oriented or right-oriented - without further auxiliary equipment.

Functions

- Output range from 0.5 – 15 l/h, up to 16 bar
- Long-range power supply unit 110 – 240 V, 50/60 Hz, IP65
- Dosing head ventilation
- Suitable for wall and floor mounting
- Material finishes PVC, PP, PVDF
- Infinitely variable dosing rate from 0 – 100 %
- CSA and UL certified

Technical specifications

MAGDOS LB		05	1	2	4	6	10	15
Delivery capacity at max. back pressure	l/h	0.36	0.76	1.9	3.4	6.2	9	13
	ml/stroke	0.05		0.2	0.32	0.57	0.83	0.87
Max. delivery pressure	bar	16				8	6	3
Delivery capacity at average back pressure	l/h	0.54	1.1	2.3	3.8	6.8	10	15
	ml/stroke	0.08	0.07	0.24	0.35	0.63	0.92	1
Average delivery pressure	bar	8				4	3	1
Nominal stroke frequency	RPM	120	250	160	180		250	
Suction lift for non-gassing media	mWS	5		3		2		
Max. supply pressure	mbar	800						
Diameter of diaphragm	mm	24		33		39		
Valve size		DN3			DN4			
Voltage supply		110 – 240 V, -10 % / +5 %, 50/60 Hz						
Power consumption	W	10	15	21	27	28	29	26
Protection class		IP65						
Insulation class		F						
Material		PVC, PP, PVDF						
Weight	kg	~ 3.2						
Permitted ambient temperature	°C	5 – 45 (with PVC parts 5 – 40)						
Permitted media temperature	°C	80 (with PVC parts 35; with PP parts 60)						

Delivery characteristic curves

These delivery capacities were determined on the manufacturer's test stands. They apply at 20 °C (68 °F) for water, at 100 % stroke frequency. The delivery capacity depends on the medium (density and viscosity) and temperature. Since these conditions vary at every installation location, you should calibrate the dosing pump.

MAGDOS LB 05 – 4

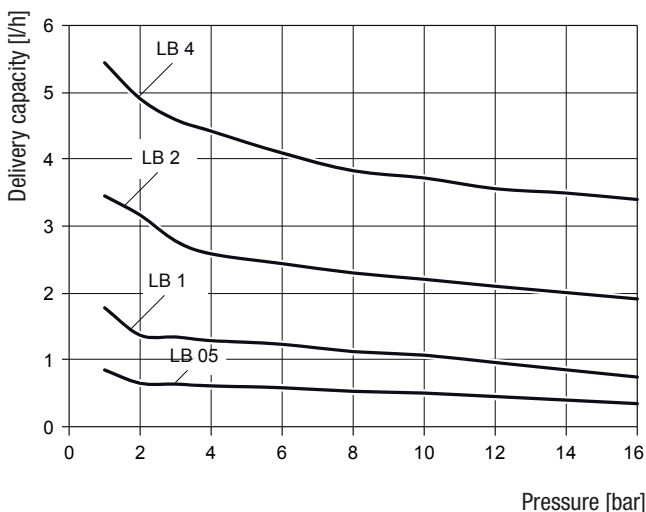

MAGDOS LB 6 – 15

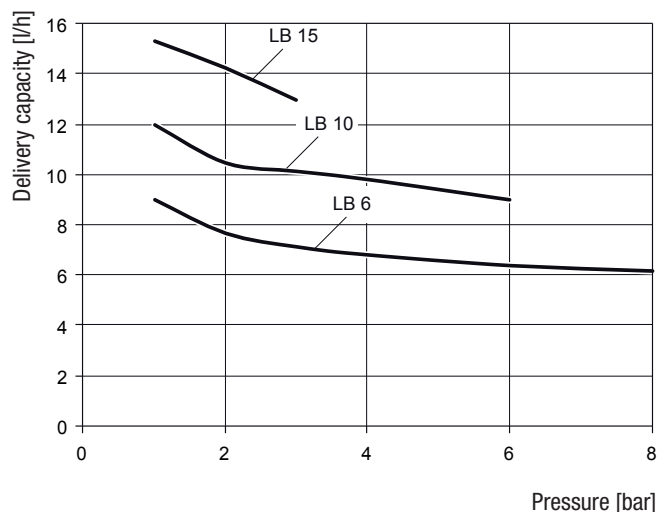

Dimensions

MAGDOS LB with dosing head made of PVC, PP or PVDF

All dimensions in mm

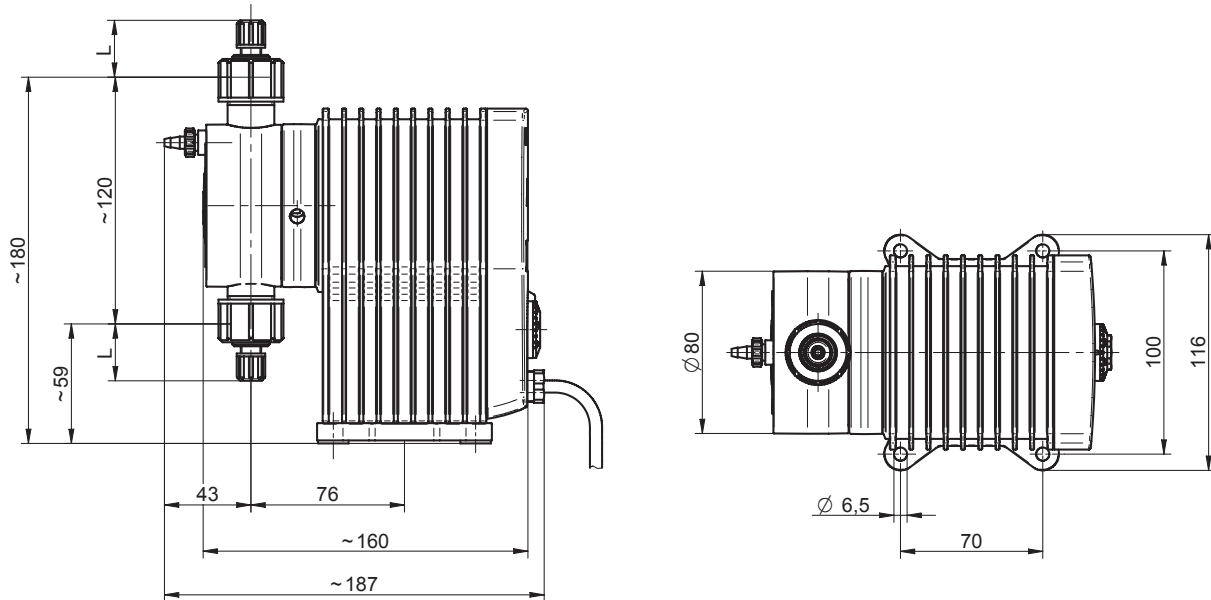

Connection	Material	MAGDOS	Scale	Nominal width	L
Hose clamp connection	PVC, PP, PVDF	LB 05 – 4	4/6 mm	DN4	31 mm
		LB 2 – 15	6/9 mm	DN6	34 mm
			6/12 mm	DN6	15 mm

You will receive further connection possibilities for your dosing pump upon request.

MAGDOS LB standard - accessories



Suction lines

Flexible suction line, SA model with foot valve and load part made from ceramic and 2500 mm hose length.

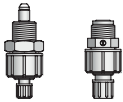

Injection nozzles

From the connection of the dosing line to the dosing point.

Injection nozzle type S, hose-loaded, opening pressure 1.1 bar

Injection nozzle type R, spring-loaded, opening pressure 0.1 bar



Suction and pressure tube

Permissible operating pressure at 20 °C in accordance with DIN EN ISO 7751, chemical resistance and correct connection are assumed.

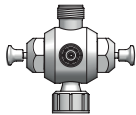

PENTABLOC

The PENTABLOC multi-function valve is installed directly on the dosing head of the pump and contains the following features:

- Back pressure function, opening pressure 3 bar
- Pressure relief function, opening pressure 11 bar
- Antisiphon function
- Dosing monitoring function

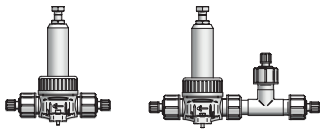

Back pressure and pressure relief valves

Back pressure valves to be mounted in the dosing line.
Adjustable pressure 1 – 16 bar

Pressure relief valves to be mounted in the dosing line.
Adjustable pressure 1 – 16 bar

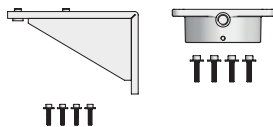

Wall bracket and connecting piece

Wall bracket including mounting material for mounting pumps. Material: PP

Connecting piece and mounting hardware required to fit the pump to a water meter. Material: Cast aluminium, coated