

### General

Diaphragm metering pumps of the MEMDOS MR series have been developed for a broad range of applications in metering technology. Thus they are used in the industrial sector, in process engineering and very frequently in water and waste water treatment. Diaphragm metering pumps are leakproof.

Standard versions are metering pumps with the head located on the left-hand side.

Type MR...L (Symbol )

Upon request, metering pumps with the head on the right-hand side can be supplied.

Type MR...R (Symbol )

Duplex metering pumps are available with the head combinations shown in the following tables. The heads are arranged in diagonals.

Type ZMR.../... (Symbol )

The power of the motor is the same for simplex and duplex metering pumps because the diaphragms operate in a push-pull arrangement.

### Metering Head

The heads are available in polypropylene and stainless steel. Special materials upon request.

Suction and discharge valves are double-ball valves up to the MR 290 version; for the bigger pumps, spring-loaded flat-seat valves are used. For viscous media of 400 mPas and more, spring-loaded single-ball valves are recommended for the suction and the discharge side. The opening pressure of the valve is about 0.1 bar.

### Separating chamber

The diaphragm flanges have been designed so that, in the case of a diaphragm rupture due to wear, no chemical can escape randomly from the pump or enter the gear. The leakage is routed downwards through a drain pipe. The diaphragm flanges thus function as a separating chamber and are protected against aggressive media by means of powdery epoxy coating. The escaping leakage can be detected by a leakage probe causing the pump to be stopped (see MB 1 31 01).

### Drive

The drive unit consists of an oil-filled worm gear. The stroke is generated by an eccentric which moves back and forth a spring-loaded plunger fixed to the diaphragm. The metering stroke is achieved by the pushing force of the eccentric, the resetting of the spring causes the suction stroke. The stroke length is set by limiting the plunger return by means of a manually adjustable eccentric disk used as a stop.



The stroke length which determines the metering capacity can be adjusted manually during operation between 0 and 100 %.

The standard version is equipped with manual adjustment. Upon request, an automatic remote adjustment (ATE) can be supplied.

### Functional diagram

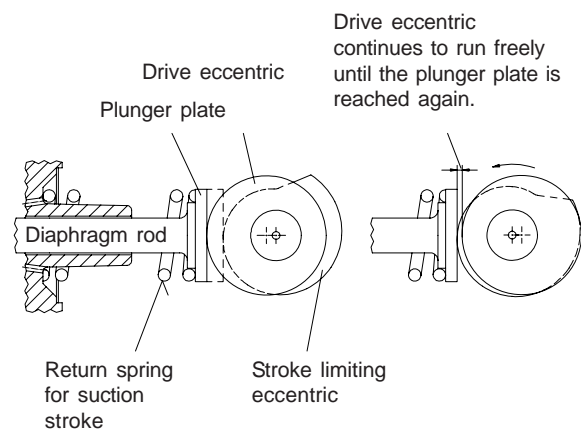

**Technical data**

The capacity is valid at 50 Hz operation.

**Simplex metering pumps**

Memdos MR		400	600	980
max. pressure	bar	5	5	4
at max. pressure	l/h	440	640	990
	ml/stroke	165	165	165
strokes/min		47	70	101
diaphragm ø	mm	185	185	185
weight	kg plastic	38	38	38
	SS	48	48	48

**Duplex metering pumps with equal heads**

Memdos ZMR		50/50	75/75	115/115	140/140	210/210	290/290	400/400	600/600	980/980
max. pressure	bar	10	10	10	10	10	10	5	5	4
at max. pressure	l/h	50/50	90/90	135/135	160/160	240/240	290/290	440/440	640/640	990/990
	ml/stroke	20	20	20	37	37	48	165	165	165
strokes/min		47	70	101	70	101	101	47	70	101
diaphragm ø	mm	90	90	90	120	120	150	185	185	185
weight	kg plastic	38	38	38	38	38	40	50	50	50
	SS	48	48	48	48	48	53	60	60	60

**Duplex metering pumps with different heads**

Memdos ZMR		50/400		75/140		75/600		115/210		115/290		115/980		140/600		210/290		210/980		290/980	
max. press.	bar	10	5	10	10	10	5	10	10	10	10	10	4	10	5	10	10	10	4	10	4
at max. pressure	l/h	55	440	90	160	90	640	135	240	135	290	135	990	160	640	240	290	240	990	290	990
	ml/stroke	20	165	20	37	20	165	20	37	20	48	20	165	37	165	37	48	37	165	48	165
strokes/min.		47		70		70		101		101		101		70		101		101		101	
diaphragm ø	mm	90	185	90	120	90	185	90	120	90	150	90	185	120	185	120	150	120	185	150	185
weight	kg plastic	49		38		49		38		40		41		41		40		49		49	
	SS	55		48		55		48		53		55		55		50		55		55	

 Max. supply pressure ( $\Sigma$  static + dynamic): 500 mbar

**Additional components**

Upon request, the metering pump can be supplied with an inductive sensor for the eccentric shaft allowing to use the number of strokes for batch processes.

**Accessories**
*Thyristor controller*

for the control of a d.c. drive (see MB 4 20 01).

For further accessories see "Installation example".

*Frequency converter*

for the control of 3-phase motors. In the case frequency converter operation, a 0.75 kW motor and an external vent must be used.

**Performance curves**

run with water, suction lift about 0.5 m

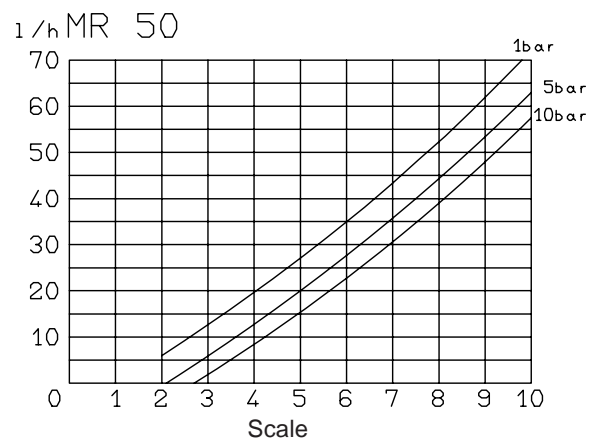

**Performance curves**

run with water, suction lift approx. 0.5 m

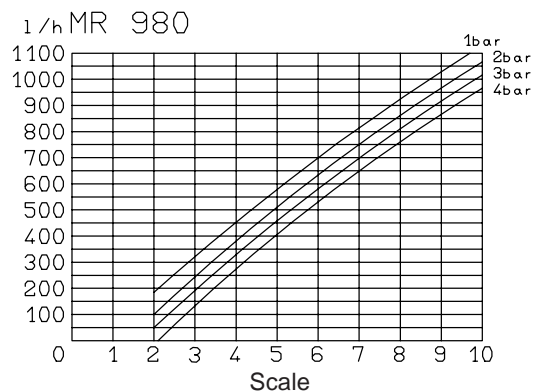
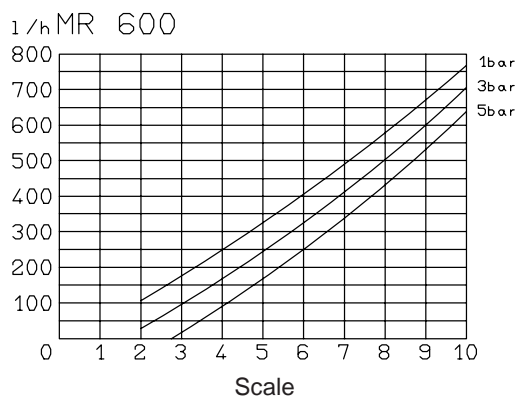
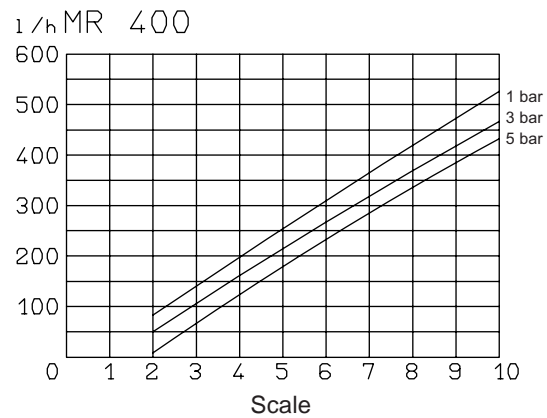
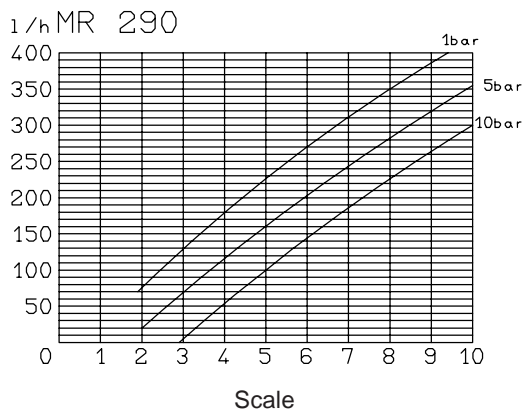
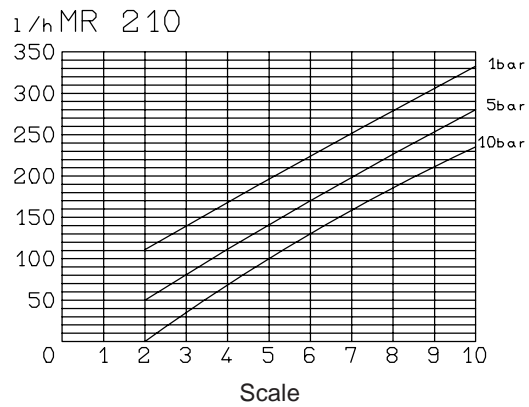
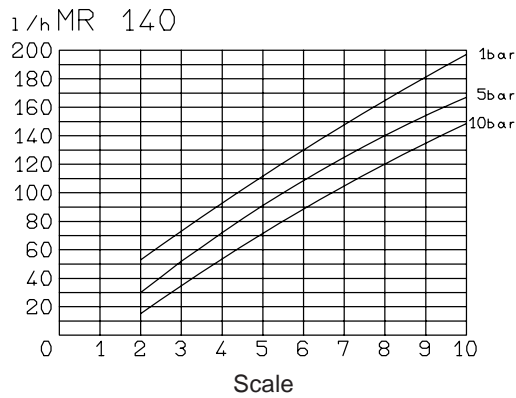
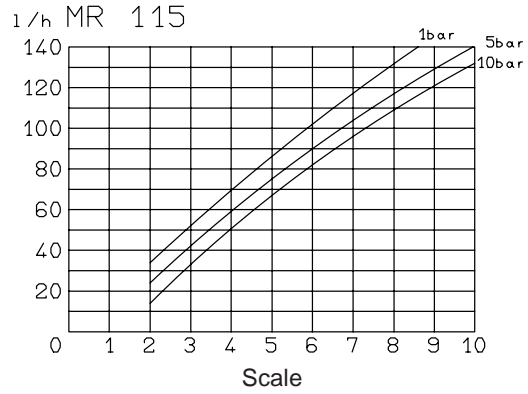
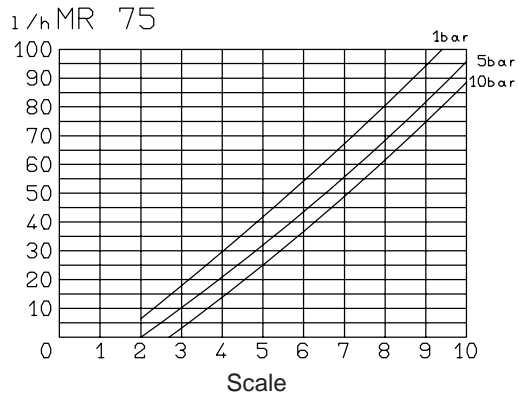

**Simplex pumps**

Left-hand version

MR 50 L . . . MR 980 L

Right-hand version

MR 50 R . . . MR 980 R

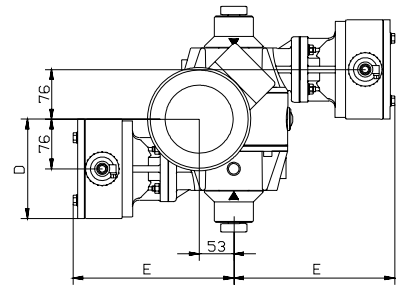
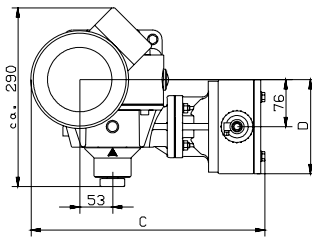
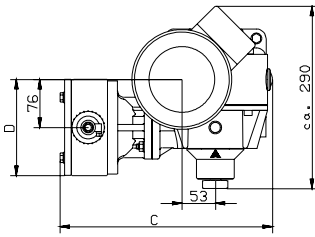
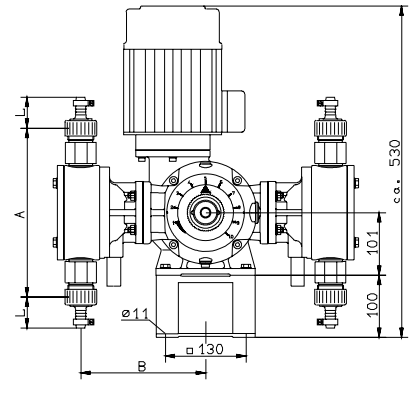
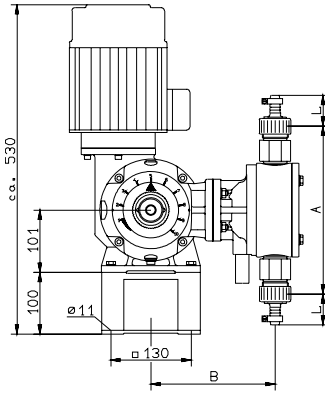
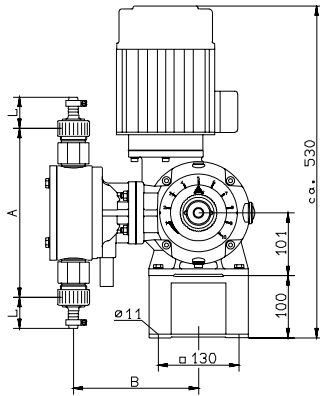
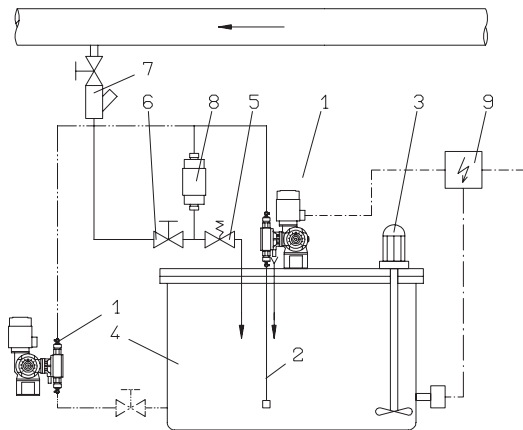
**Duplex pumps**

**Installation example**

In the case of duplex pumps with different metering heads the larger head must always be located on the left-hand side (L); for possible head combinations see table MB 1 05 02 / 5.

**Dimensions**

Model MR	A	B	C	D	E
50	272	201	370	∅152	228
75	272	201	370	∅152	228
115	272	201	370	∅152	228
140	272	201	370	∅152	228
210	272	201	370	∅152	228
290	296	201	370	□170	225
400	265	225	425	∅230	300
600	265	225	425	∅230	300
980	265	225	425	∅230	300

**Legend**

- |                           |            |
|---------------------------|------------|
| 1 Metering pump MEMDOS MR | MB 1 05 02 |
| 2 Suction line            | MB 1 22 01 |
| 3 Electric agitator       | MB 1 36 03 |
| 4 Tank                    | MB 1 20 01 |
| 5 Relief valve            | MB 1 25 01 |
| 6 Diaphragm shutoff valve | MB 1 24 01 |
| 7 Injection nozzle        | MB 1 23 01 |
| 8 Pulsation dampener      | MB 1 27 01 |
| 9 Switchbox               |            |

Dimension L see selection table 5, page 7.

**Selection tables**

In order to offer the user a wide variety of pumps, the metering pumps have been divided into the most important functional groups. The pump can be made up according to the individual requirements.

Select the pump from the following modules:

- 1** Gear      **2** Motor      **3** Head
- 4** Valves    **5** Connections

The numbers on the pump drawing refer to the corresponding selection tables.

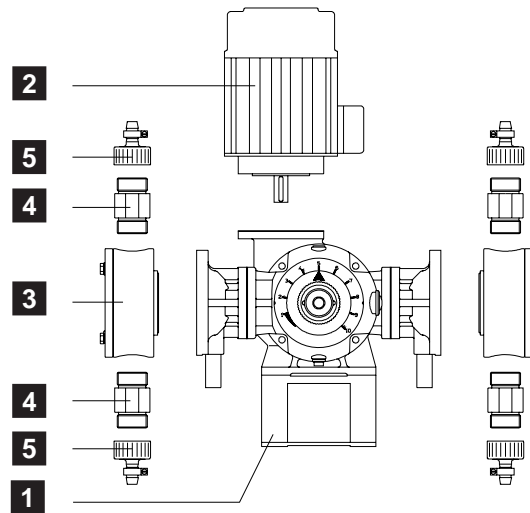

<b>1</b>				
Pump model MR	Simplex pumps			
	Left-hand version L		Right-hand version R	
	Capacity adjustment			
	manual	ATE	manual	ATE
400	31247	31248	31440	31441
600	31249	31250	31442	31443
980	31251	31252	31444	31445

<b>1</b>			
Pump model ZMR	Duplex pumps with different heads		
	Capacity adjustment		
	Symbol	manual	ATE
400/50		31653	31654
140/75		31655	31656
600/75		31657	31658
210/115		31659	31660
290/115		31661	31662
980/115		31663	31664
600/140		31665	31666
290/210		31667	31668
980/210		31669	31670
980/290		31671	31672

<b>1</b>			
Pump model ZMR	Duplex pumps with equal heads		
	Capacity adjustment		
	Symbol	manual	ATE
50/50		31253	31254
75/75		31647	31648
115/115		31681	31682
140/140		31649	31650
210/210		31683	31684
290/290		31251	31652
400/400		31261	31262
600/600		31267	31268
980/980		31271	31272

<b>3</b>			
Pump model MR	Heads		
	Diaphragm ø	PP	1.4571
50	90	23721	23727
75		23721	23727
115		23721	23727
140	120	23722	23728
210		23722	22728
290	150	23723	22334
400		23735	23736
600	185	23735	23736
980		23735	23736

Diaphragm metering pump MEMDOS MR

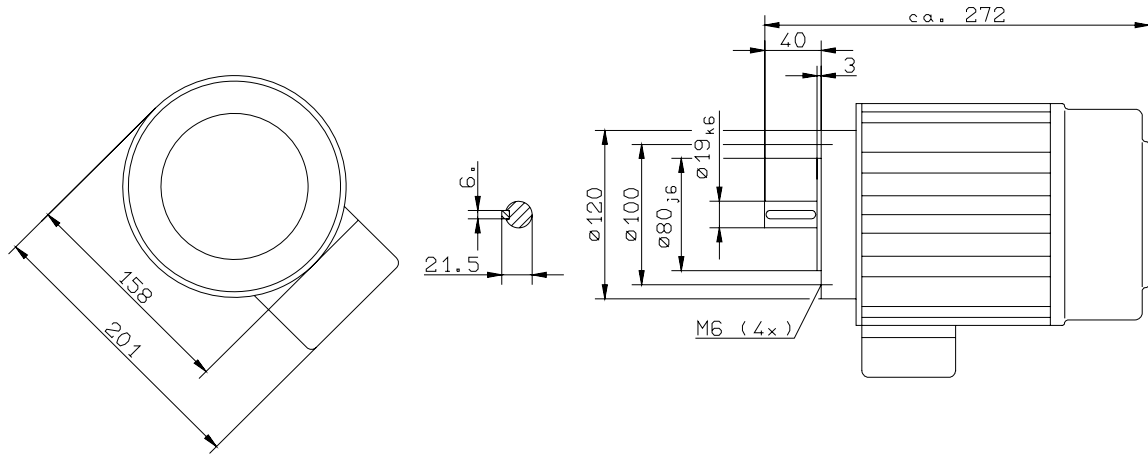

2									
E. motor type	Part No.	Circuit	Voltage V	Current consumption A	Power kW	Speed 1/min	Frequency Hz	Prot. Class	
								ISO Cl.	IP
AF 80 / 4A-11	78629	Δ Y	230/400	2.6 / 1.55	0.55	1390	50	F	55
AF 80 / 4B-11	78903	Δ Y	230/400	3.5 / 2.0	0.75	1400	50	F	55
AF 80 / 4B-11	78982	Δ Y	230/400	3.5 / 2.0	0.75	1400	50	F*	55

\* Motor fitted with cold-conductor thermometer probe

4											
Pump model MR	<b>Standard valves</b>										
	MR 50...290: double-ball MR 400...980: spring-loaded with Hastelloy spring (disk valves as of 08.97)										
	Suction valve assembly						Discharge valve assembly				
	PP			1.4571			PP		1.4571		
	Seals of:										
	Hypalon	Viton	AF	Hypalon	Viton	Hypalon	Viton	AF	Hypalon	Viton	
50 ... 290	26841	26842	29694	—	—	27356	27357	29695	—	—	
400 ... 980	23703	23704	—	23705	25681	23703	23704	—	23705	25681	
Pump model MR	<b>Spring-loaded valves with Hastelloy spring</b>										
	Suction valve assembly						Discharge valve assembly				
	PP			1.4571			PP		1.4571		
	Seals of:										
		Hypalon	Viton	AF	Hypalon	Viton	Hypalon	Viton	AF	Hypalon	Viton
50 ... 290	26845	25707	29696	—	—	27353	27354	29697	—	—	

AF = asbestos-free

<b>5</b>									
Pump Model	Dimensions					Part No. Version			
	MR	DN	Abb.	di	da	L	PVC	PP	St. steel
50	8	C	-	12	22	25923	-	-	-
		E	-	10	51	-	-	-	25926
115	10	B	9	15	41	25921	-	-	25925
		C	-	16	22	27672	27664	-	-
		D	-	G 3/8	22	25930	33797	27037	-
50	15	B	16	26	50	25936	35649	25935	-
		C	-	20	22	25937	35490	-	-
75	15	C	-	20	22	25937	35490	-	-
115		D	-	G 1/2	22	25943	33798	25944	-
140	15	E	-	18	44	-	-	25939	-
210		F	-	-	47	25956	-	-	-
290	15	F	-	-	53	-	-	25957	-
400		D1	-	G 3/4	40	24076	-	24065	-
400	25	B1	25	34	70	24034	-	24063	-
600		C1	-	32	40	21488	33770	-	-
980		D1	-	G1	40	28458	34717	27040	-
		E1	-	28	80	-	-	27852	-
		F1	-	-	60	25622	-	25623	-
		G1	-	32	75	34050	34570	-	-
32	C1	-	40	44	21491	34828	-	-	
	D1	-	G 1 1/4	40	-	32759	25252	-	

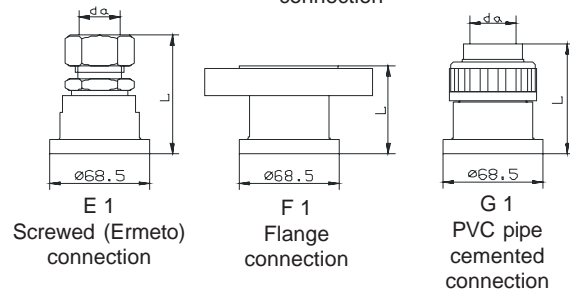
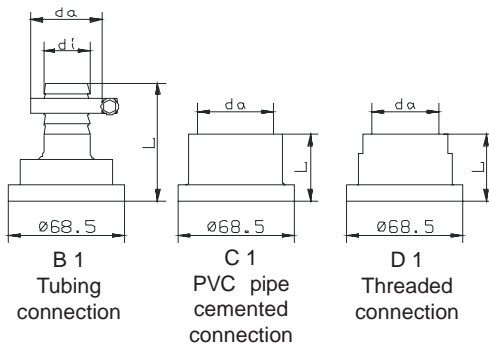
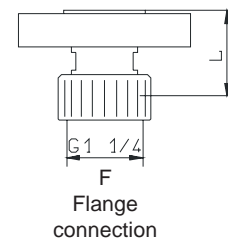
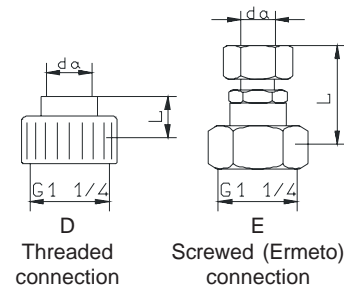
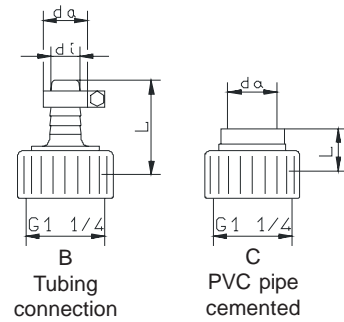

### Order example

For metering aluminum sulfate and sodium hypochlorite, metering pumps are required.

Given operating data:

380 l/h aluminum sulfate, max. pressure 4 bar

45 l/h sodium hypochlorite, max. pressure 3 bar

Mains voltage: 230/400 V, 50 Hz

In this example, both chemicals shall be metered at a fixed ratio. Therefore a manually adjustable duplex pump ZMR 400/50 should be ordered.

Resistant head material: PP

The suction and discharge valves are determined according to the resistance of the sealing materials. Hypalon is resistant to aluminum sulfate. Viton is resistant to sodium hypochlorite.

### The order reads as follows:

The metering pump is made up of the following modules:

<b>1</b>	Gear ZMR 400/50	Part No. 31653
<b>2</b>	Drive motor	78629
<b>3</b>	Head for MR 400	23735
	Head for MR 50	23721
<b>4</b>	Suction valve for MR 400	23703
	Discharge valve for MR 400	23703
	Suction valve for MR 50	26842
	Discharge valve for MR 50	27357
<b>5</b>	Suction connection for MR 400	24034
	Discharge connection for MR 400	24076
	Suction connection for MR 50	25936
	Discharge connection for MR 50	27672





**General**

Metering pumps for use as correcting elements in automatic control systems or control lines are equipped with electrical servomotors. Thus the stroke length can be adjusted by sender-key contacts or controllers with relay output. In the case of duplex pumps, each head may be fitted with a separate servomotor and adjusted independently.

The pumps are identified by the letters ATE added to the model:

e.g. MR 50 L - ATE

Mechanical manual adjustment of the pumps with ATE drive is possible by using a separate hand crank.

The non-linear performance curve of the diaphragm metering pumps remains despite all linear mechanics of the stroke adjustment. Therefore the performance curve of the pump must be taken into consideration in the case of controls without feedback of the metering result (proportional metering).

Two products with different technical data are available (see pages 10 and 11).

Upon request, also "increased safety"-type or "air-tight" servomotors can be supplied.



**Dimensions**

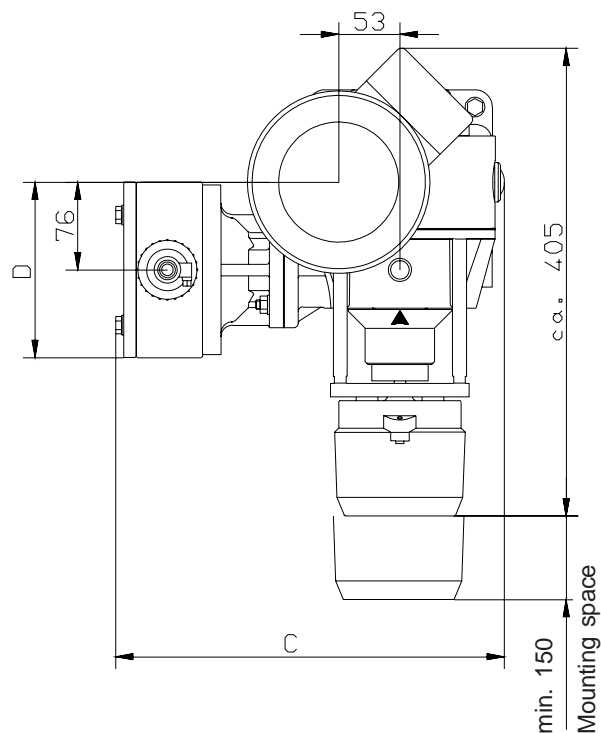
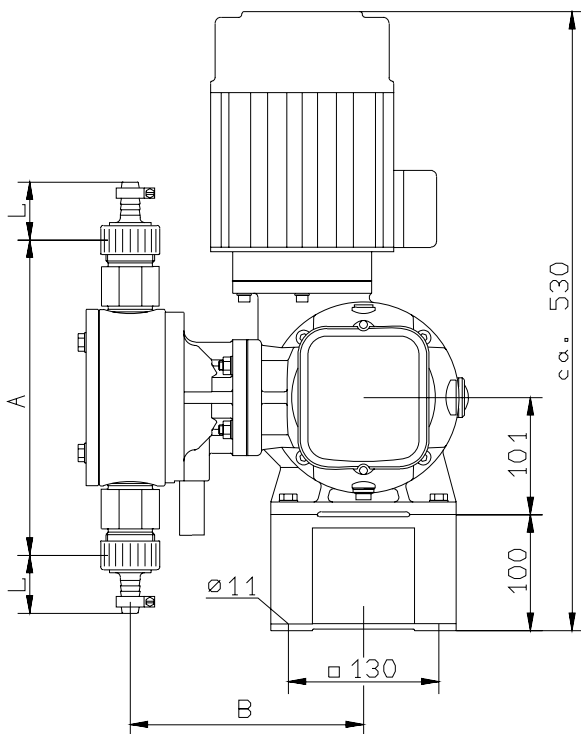

Dimension A, B, C, D, see MB 1 05 02 / 4

Technical data, types AR 30W23 and AR 30W23S

Type	AR 30W..	AR 30W..S
Design	Reversible a.c. motor with self-locking reduction gear	
Use	for controllers with switching output (3-point control)	for controllers with continuous output (2...10V or 4...20mA)
Auxiliary voltage	230V~ ± 15% 50...60 Hz	24V ~ ± 20% 50...60 Hz
Control		2...10V or 4...20mA
Power consumption	2 W	7 W
Regulating time/bevel	360s / 270° = 0...100%	
Position repeating signaling for remote display	Potentiometer 0.5 W 0...1000 Ω = 0...100%	0...620mV = 0...100%
Limit switch	Internal limit switches for limiting angle of rotation. Signaling of final position via terminals 16 and 17	Internal limit switches for limiting angle of rotation.
Protection class	IP 55 (EN 60529)	
Ambient temperature	-20 ... 60°C	
<b>Options</b>		
2nd potentiometer	0...1000 Ω 0.5 W	
Limit switches (2 off)	max. 250V 1A	

Wiring diagrams

Types AR 30W23 F001 230V~ and AR 30W23 F020 24V ~

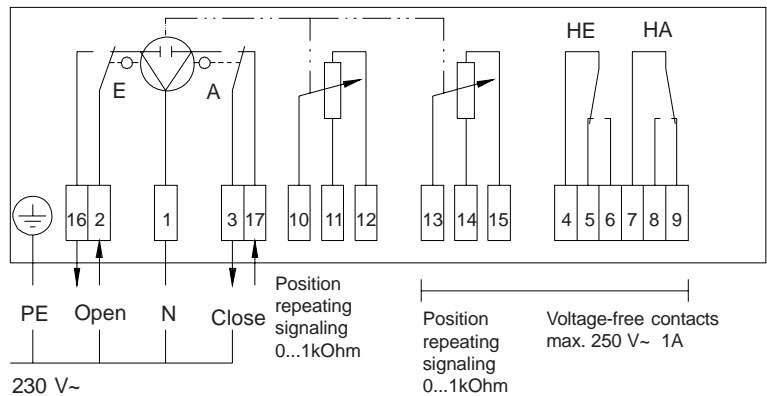

Type AR 30W23S F020 24V~

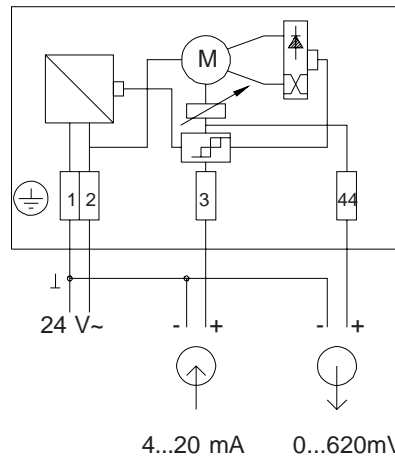

## Technical data, types WAN 1 and WAN 1-S

Type	WAN 1	WAN 1-S
Design	Reversible a.c. motor with self-locking reduction gear	
Use	for controllers with switching output (3-point control)	for controllers with continuous output 0(4)...20mA
Auxiliary voltage	230V~ ± 10% 50...60 Hz Other voltages upon request	230V~ ± 10% 50...60Hz
Control		0(4)...20mA
Power consumption	approx. 11.5 W	
Regulating time/bevel	360s / 270° = 0...100%	
Position repeating signaling for remote display	Potentiometer 0.5 W 0...1000 Ω = 0...100%	0(4)...20mA (as an option only)
Limit switch	Internal limit switches for limiting the angle of rotation. Signaling of the final position via terminals 4 and 5	
Protection class	IP 54 according to DIN 40050	
Ambient temperature	max. 60°C	
<b>Options</b>		
2nd potentiometer	0...1000 Ω 0.5 W	
Limit switches (2 off)	max. 250V 1A	

## Electrical wiring diagrams

## WAN 1

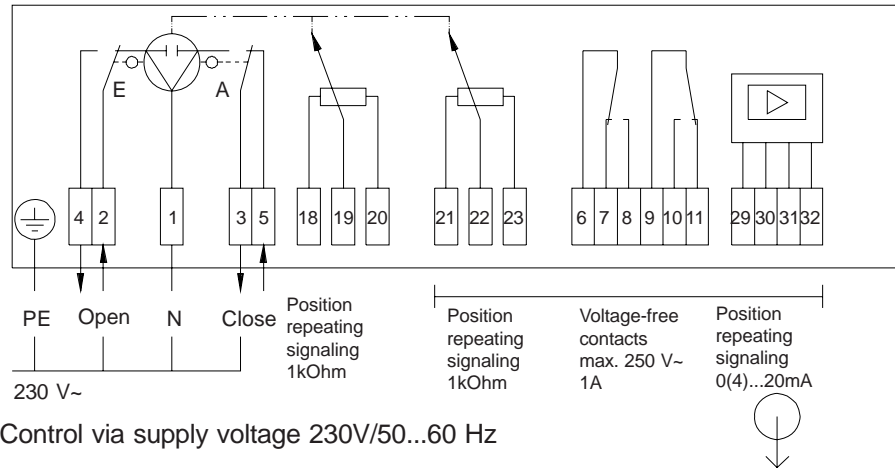

## WAN 1-S

